



COMMERCIAL MIXERS

GEM160 60 Quart Mixer

Project Name:

Location:

Item:

Qty.:

Model:



GEM160
60 Quart Mixer

FEATURE LIST

Model:	GEM160
Description:	60 Quart Mixer
Voltage:	220/50-60/1, 220/50-60/3
Rated Power:	2200 Watts
Bowl Capacity:	60 qt
Speed:	65-374 RPM
Weight:	739 lb / 336 kg
Dimensions:	32" W x 44" D x 54" H 810mm W x 966mm D x1372mm H

Designed for heavy duty applications where a planetary mixing action is required. These all-purpose mixers use a planetary mixing action that consistently blends, mixes and aerates all ingredients with satisfactory results. The heat treated carbon steel gears deliver energy at three pre-selected fixed speeds. Each mixer comes standard with a stainless steel bowl, flat beater, spiral dough

hook, and wire whip. The stainless steel wire front bowl guard opens easily for adding ingredients. The bowl guard magnetic lock prevents the mixer from running if guard is opened or the bowl is lowered. The switches are moisture resistant. All units come with an overload switch which protects the motor.



Specifications subject to change without notice.

Approvals:



GENERAL

3355 Enterprise Ave • Suite 160 • Ft. Lauderdale, FL 33331

Tel: 954.202.7419 • Fax: 954.202.7337 • www.asburyfoodservice.com

Asbury Foodservice's continuing commitment to quality products may mean a change in specification or pricing without notice.



PLAN VIEW

GEM160 60 Quart Mixer

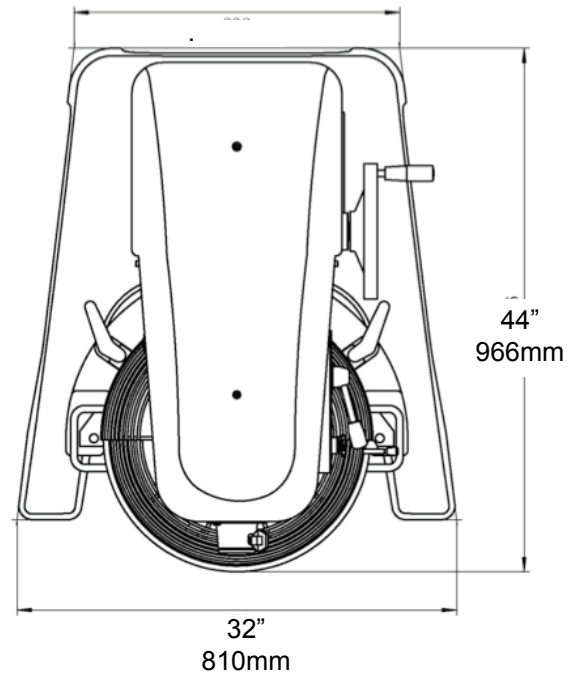
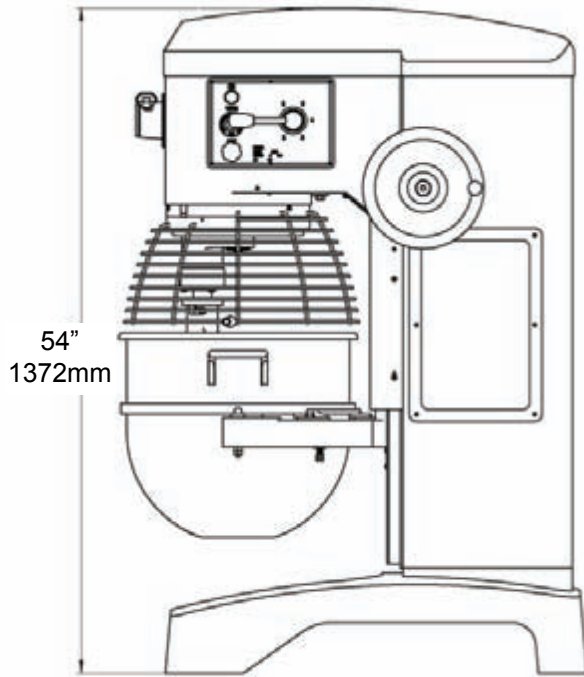

Dimensional Data

Model	Description	Voltage	Rated Power	Bowl Capacity	Speed	Weight
GEM160	60 Quart Mixer	220/50-60/1 220/50-60/3	2200 Watts	60 qt	65-374 RPM	739 lb / 336 kg

- Standard #12 PTO Hub
- 4 Speed gear driven direct drive transmission
- Manufactures with a heavy duty, all cast frame construction
- Includes beater, dough hook, whip, and stainless steel bowl
- Standard safety features include interlocking bowl guard, bowl lift, and motor overload protection

- Tough enough to handle bread, pastry, & pizza dough, batters, toppings, and other food mixtures
- ETL/ETL Sanitation



GENERAL

3355 Enterprise Ave • Suite 160 • Ft. Lauderdale, FL 33331

Tel: 954.202.7419 • Fax: 954.202.7337 • www.asburyfoodservice.com

Asbury Foodservice's continuing commitment to quality products may mean a change in specification or pricing without notice.